



**One-Way Polyethylene Connector
(One - port type)**

USE (for 200L DRUM)

Operation Manual

Surpass Industry Co., Ltd.

Read Before Use

- Before using this product, check the compatibility of the type of liquid to use and the wetted parts material in this product.
- All users are required to carefully read and understand this manual before operation of the product.
- Keep this manual in good condition, and retain it close at hand for quick consultation whenever necessary.
- Use the product only as intended, and only as directed in this manual.
- Cautionary notes in this manual must be fully understood and complied with at all times.

About This Operation Manual





- The contents of this manual are subject to change without prior notice, due to improvements in product functionalities and / or performance.
- No part of this manual may be reproduced in any form or by any means.
- Although this manual has been prepared with all possible care, please do not hesitate to contact Surpass Industry about errors, omissions, or any other points of doubt.

Important Safety Instructions

<Symbols in This Operation Manual>

Warnings and cautionary notes are provided in this manual to ensure this product is used correctly and to prevent personal injury and property damage. The meanings of the WARNING and CAUTION symbols in this manual are as described below. Read and understand these notes before reading the rest of this manual.

In particular, fully understand and obey the instruction of **DANGER mark.**

 DANGER	<p>This symbol indicates warnings against impending danger which, if not observed, may cause death or severe injury to the user.</p>
 WARNING	<p>This symbol indicates warnings which, if not observed, may cause death or severe injury to the user.</p>
 CAUTION	<p>This symbol indicates warnings which, if not observed, may physically impair the user or damage surrounding objects.</p>
	<p>Provides important notices and indications to operate the product correctly.</p>

DANGER and WARNING Statements

General Instructions on Mounting

**DANGER**

Mandatory struction!!

Whenever using this product for hazardous chemical fluids or solvents, wear anti-chemical protective gear (protective gloves, protective mask, and protective clothing) that completely protects your body. Exposure of chemical fluids may result in personal injury.

**WARNING**

Follow the procedures provided in this manual when installing the plug and socket and piping with them. An improper way or wrong procedures may cause liquid leakage, resulting in personal injury.

Instructions on Handling

**WARNING**

Do not damage the connecting part (wound with seal-tape) of plug and socket. Damage of product may result in personal injury due to leakage of chemical fluids.

Do not contact the connector to any rigid materials because it is made of resin materials. Damage of product caused by contact may result in personal injury due to leakage of chemical fluids.

Instructions on Mounting

**DANGER**

Mandatory struction!!

Release pressure from the piping before attaching/detaching the connector. A pressurized condition may cause spouting of chemicals, resulting in personal injury.

Always wear anti-chemical protective gear (protective gloves, protective mask, and protective clothing) that protects your entire body when attaching/ detaching the connector. A contact with chemicals may cause personal injury.

Attach/detach the connector in a clean place with no dust. Degradation of sealing performance due to adhesion of dust may cause liquid leakage, resulting in personal injury.

Always attach/detach the connector at right angle to the surface of container. Attaching/detaching the connector at an angle may cause spouting of chemicals, resulting in personal injury.

When the connector is connected, make sure that the connector is fully connected. The chemicals may splash and personal injury may be caused.

Use out of the operating pressure range may result in slip-off. Be sure to use within the operating pressure range.

Do not apply the connector to rotary joint or other rotary application. Lower tackiness caused by the wrong application may result in personal injury due to leakage of chemical fluids.

**WARNING**

Follow the instructions provided by the manufacturer of your coupling to tighten a nut (Rotor) securely.

To prevent leakage from the coupling part, inspect it periodically. If any leakage detected, tighten nuts more firmly according to the appropriate brochure or instruction manual provided by the manufacturer of your coupling.

When tubing, use tubes of the specified size. Using other tubes may result in personal injury due to fluid leakage.

Refrain from excessive tightening of the connector parts. Otherwise, damage to the body and connector may occur and result in liquid leakage. The use of dangerous chemicals, solvents, and gases may cause physical impairment.



- Apply operating fluid or pure water to the O-Ring of the socket (inner) or O-Ring sliding part of the plug (sealing part) when connecting the socket or plug to prevent the O-Ring from being damaged and to reduce the slide resistance (insertion load).
- Do not use abrasive compound or fluid that is easy to clot as they may impair normal function.

Instructions on Maintenance and Inspection

**CAUTION**

Surpass Industry is not be liable to any failure or leakage of the product due to O-Ring replacement and/or disassembly performed by any parties other than Surpass Industry.

If you are not confident of success in maintenance work, please call Surpass Industry.

1. Product Description

<Applications>

USE-type Quick Connector is a handy connector used to transfer high-purity EL chemicals. It is designed for containers with the capacity of 200L, such as a CHEMICAL DRUM, POWER DRUM, which are commonly used in the semiconductor industry.

<Features>

Surpass original "Super one-touch method" enables the connection of the USE connector by one single push.

The plug has a mechanism to prevent liquid spouting, ensuring safety without any valve on the plug side.

Siphon tube is integrated into the connector, facilitating installation.

Socket on the fluid side has a prevention mechanism of liquid leakage.

Supply can be done by one port due to having a flow channel for liquid and gas on the socket side and the plug side.

2. Specification

Operating Fluid Pressure	: 0 ~ 250 kPa (36.25 psi)
Operating Environmental Temperature	: 5 ~ 40 °C (41 ~ 104 °F)
Operating Fluid Temperature	: 5 ~ 60 °C (41 ~ 140 °F)
Wetted parts	: Plug side · · · · HDPE, O-ring(FKM Standard) Socket side · · · PCTFE, PTFE, PFA, O-ring(Kalrez [®] Standard)

Kalrez[®] is registered trademarks of DuPont Performance Elastmers.



Please be careful when use abrasive compound or fluid that is easy to clot as they may impair normal function.

3. Designations of Parts

PLUG TYPE : USE-P-L-

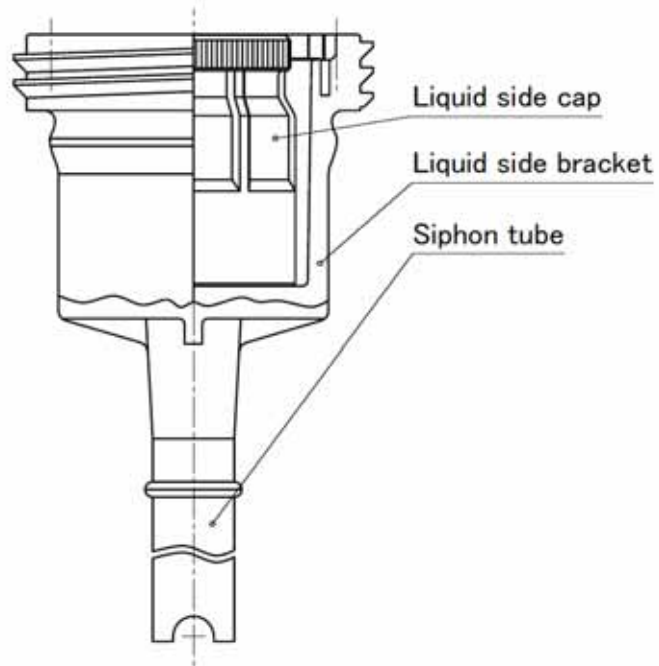

SOCKET TYPE : USE6F-SGR,USE-SGR

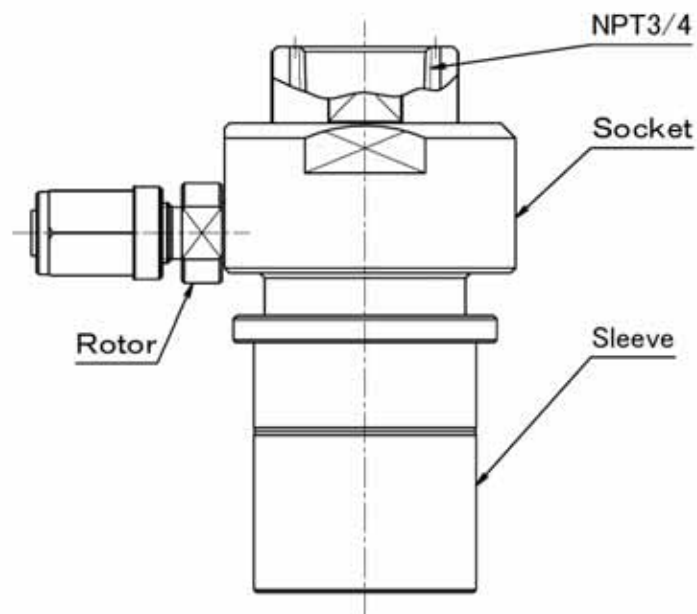

4. Reference example

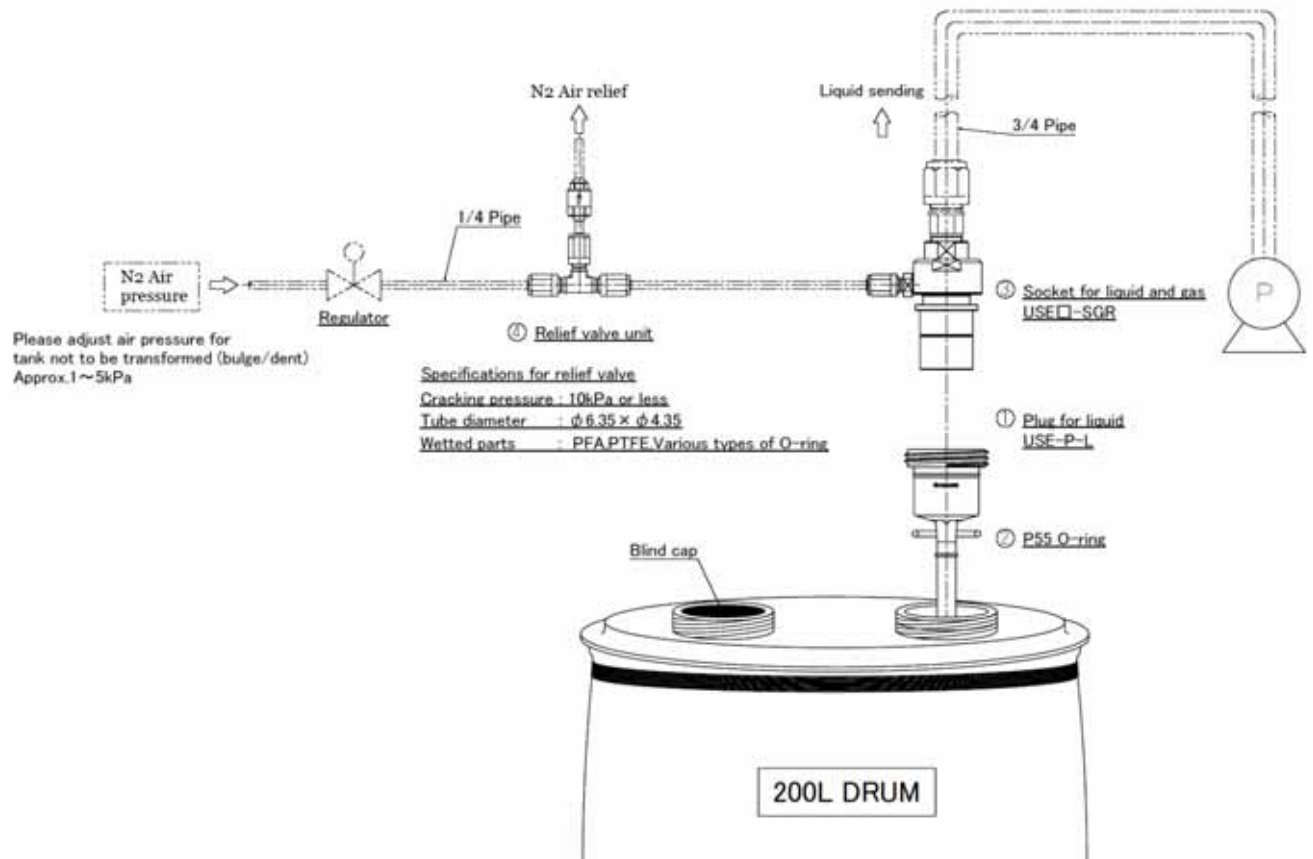

Relief valve unit is optional.

5. List of Jigs Used





Jigs are optional. Please contact us and order your desired jig by its product name and designation listed in the table below.

Jig used to mount/remove the USE plug to/from the drum.

	Product name: Bracket attaching/removing jig
	Designation: PDC-AIN
	Application: <ul style="list-style-type: none"> • Mounting of the USE plug to the drum • Removing of the USE plug from the drum

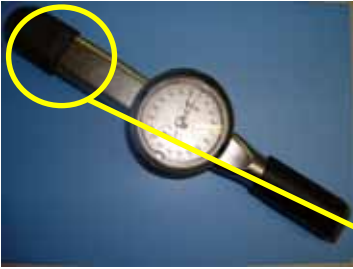

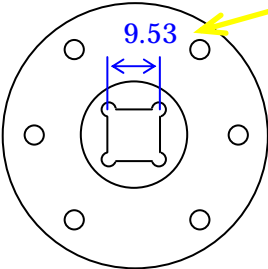
PRELIMINARY Torque wrench (The following can be used.)

Application : Mounting of the USE plug	
DB50N-S (Tohnichi Mfg.Co.,Ltd)	
	
PDC-AIN A mount size	
Mounting standard : For torque wrench of the standard head size is 9.53.	

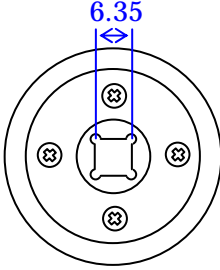
jig used to attach/remove the cap

	Product name : Cap attaching/removing jig
	Designation : USE-TOOL
	Application : <ul style="list-style-type: none"> • Attaching the cap to the bracket-embedded plug • Removing the cap from the bracket-embedded plug
USE-TOOL A mount size	

PRELIMINARY Torque wrench (The following can be used.)

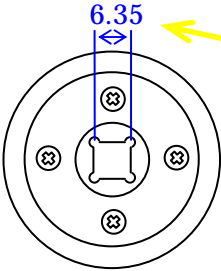
Application : Mounting and removing of the cap	
DB3N4-S (Tohnichi Mfg.Co.,Ltd)	
	
USE-TOOL A mount size	
Mounting standard : For torque wrench of the standard head size is 6.35.	

6. Installation

**DANGER**

Mandatory struction!!

Whenever using this product for hazardous chemical fluids or solvents, wear anti-chemical protective gear (protective gloves, protective mask, and protective clothing) that completely protects your body. Exposure of chemical fluids may result in personal injury.

6-1 Unpacking

Be careful not to damage the plug and socket when unpacking.

6-2 Preparing a container

Prepare a container with the capacity of 200 liters (see the photo showing the container with the caps being attached).



* Prepare for the installation after confirming that the screws of the container and USE are compatible.
(Please contact our sales staff for any questions.)

Remove the caps from the container. (See the photo below.)



Check the bracket mounting part of the container for adhesion of foreign substances. If any foreign substance is found adhered, remove it.

6-3 Mounting the Plug

WARNING

Follow the procedures provided in this manual when mounting the plug. An improper way or wrong procedure of mounting the plug may cause an accident such as liquid leakage, resulting in personal injury.

Insert a drum O-ring into the bracket of plug. (See the photo and Figure 1 below.)

(1)

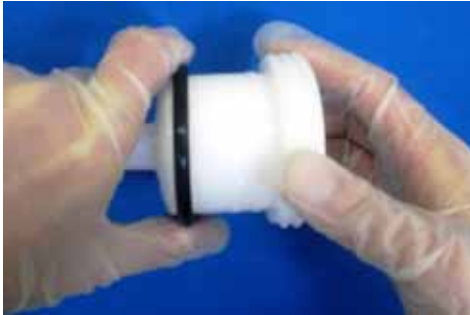

(2)

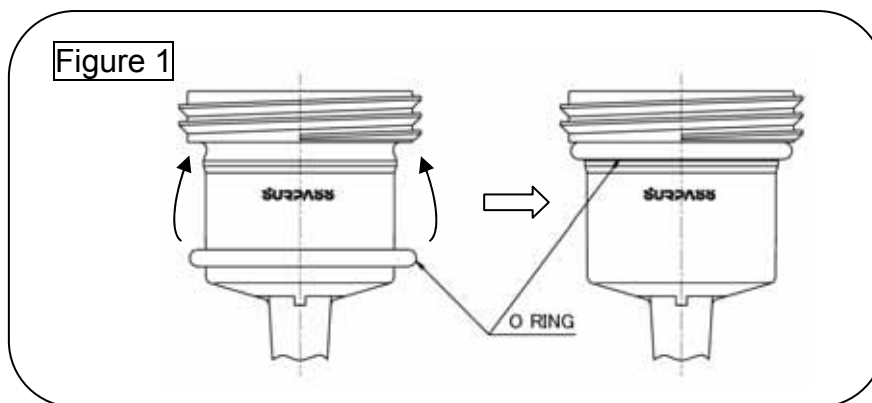
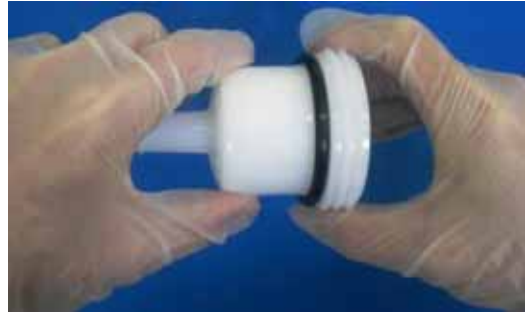

Mount the plug in the container. (See the photo and Figure 2 below.)

Torque : 20 ~ 25[N·m]

CAUTION

Use a drum O-ring which is made of rubber (size: P55) and it with **20 ~ 25 [N·m]** of torque. Excessive or inadequate tightening may cause breakage or liquid leakage.

(1)

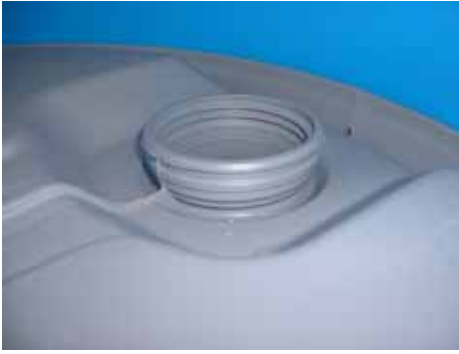

(2)



(3)



(4)



(5)

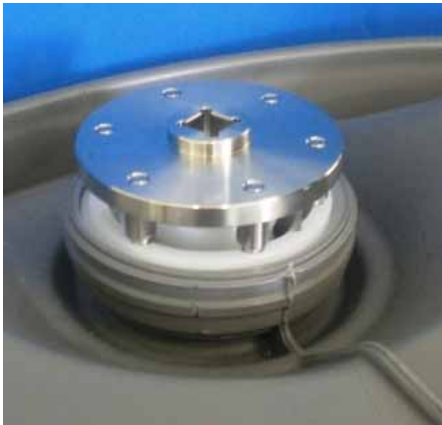

(6)



Tighten the plug with
20 ~ 25 [N · m].

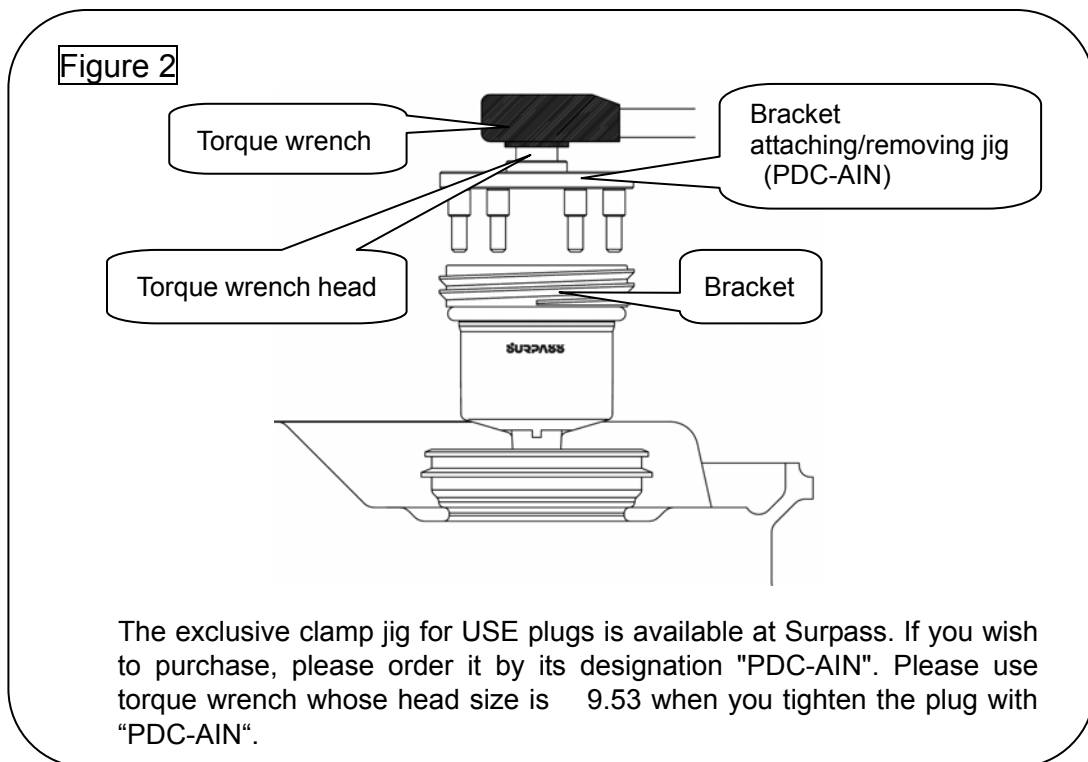

7. Piping with the Socket

Wrap PTFE sealing tape around the connecting part (male thread) three or four times, and screw it into the NPT female thread of the socket.

WARNING

Use the taper threads (socket side) and the metric threads (plug side) in the specified usage and procedures. Using the taper threads in the wrong usage or procedures may result in personal injury due to leakage of chemical fluids.



- Always use a NPT male thread since the female thread of the socket for piping is compliant with the American standard pipe taper thread (NPT).
- For a male thread, use one that is made of the resin (PTFE, PCTFE, PFA, PE, or pp) but rigid materials such as metallic. Using a male thread made of rigid materials may break the female thread, resulting in liquid leakage.

— Taper thread specifications —
Socket : NPT 3/4

- Tighten the male thread with the correct value of torque. Excessive tightening may break the product.
- After screwing the male thread, perform the leakage test to confirm that the connecting part has no leakage.

8. Attaching Procedure



DANGER

Mandatory instruction!!

Release pressure from the piping before attaching/detaching the connector. A pressurized condition may cause spouting of chemicals, resulting in personal injury.

Always wear anti-chemical protective gear (protective gloves, protective mask, and protective clothing) that protects your entire body when attaching/ detaching the connector. A contact with chemicals may cause personal injury.

Attach/detach the connector in a clean place with no dust. Degradation of sealing performance due to adhesion of dust may cause liquid leakage, resulting in personal injury. Always attach/detach the connector at right angle to the surface of container. Attaching/detaching the connector at an angle may cause spouting of chemicals, resulting in personal injury.

When the connector is connected, make sure that the connector is fully connected. The chemicals may splash and personal injury may be caused.

Use out of the operating pressure range may result in slip-off. Be sure to use within the operating pressure range.

Do not apply the connector to rotary joint or other rotary application. Lower tackiness caused by the wrong application may result in personal injury due to leakage of chemical fluids.



WARNING

Follow the instructions provided by the manufacturer of your coupling to tighten a nut (Rotor) securely.

To prevent leakage from the coupling part, inspect it periodically. If any leakage detected, tighten nuts more firmly according to the appropriate brochure or instruction manual provided by the manufacturer of your coupling.

When tubing, use tubes of the specified size. Using other tubes may result in personal injury due to fluid leakage.

Refrain from excessive tightening of the connector parts. Otherwise, damage to the body and connector may occur and result in liquid leakage. The use of dangerous chemicals, solvents, and gases may cause physical impairment.



- Apply operating fluid or pure water to the O-Ring of the socket (inner) or O-Ring sliding part of the plug (sealing part) when connecting the socket or plug to prevent the O-Ring from being damaged and to reduce the slide resistance (insertion load).
- Do not use abrasive compound or fluid that is easy to clot as they may impair normal function.

8-1 Removing the Cap

Confirm that the container is not pressurized (with no pressure applied).



DANGER

Mandatory struction!!

Release pressure from the piping before removing the cap. A pressurized condition may cause spouting of chemicals, resulting in personal injury.

Slowly remove the cap. (See the photo and Figure 3 below.)



* Torque wrench is not necessary when the cap is removed.

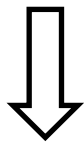

When depressure sound and gas discharge sound can be heard in a cap at the time of removal work, please interrupt work and resume work after checking that depressure sound and discharge sound have disappeared.



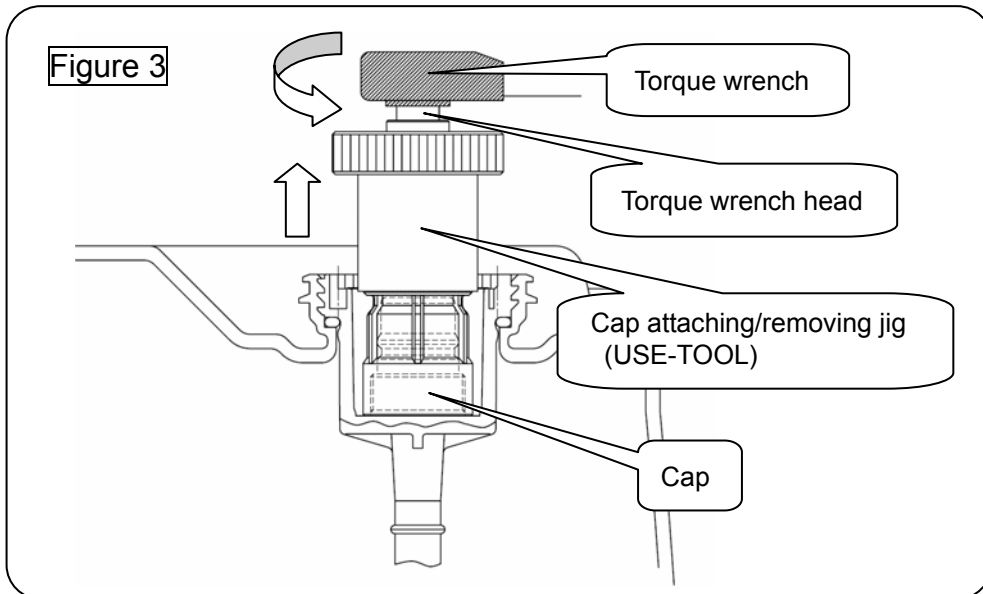

Surpass Industry provides our special tightening jig designed for mounting the cap. If you need, please order us by model type "USE-TOOL". Please use torque wrench whose head size is 6.35 when you tighten the plug with "USE-TOOL".



When depressure sound and gas discharge sound can be heard in a cap at the time of removal work, please interrupt work and resume work after checking that depressure sound and discharge sound have disappeared.

8-2 Attaching the socket

Confirm that the container is not pressurized (with no pressure applied).



DANGER

Mandatory struction!!

Release pressure from the piping before attaching the connector. A pressurized condition may cause spouting of chemicals, resulting in personal injury.
Connect the tube without any moment or tension to bend the joint portion.

Hold the socket and insert it into the plug straightly. (See the photo and Figure 4 below.)

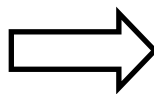
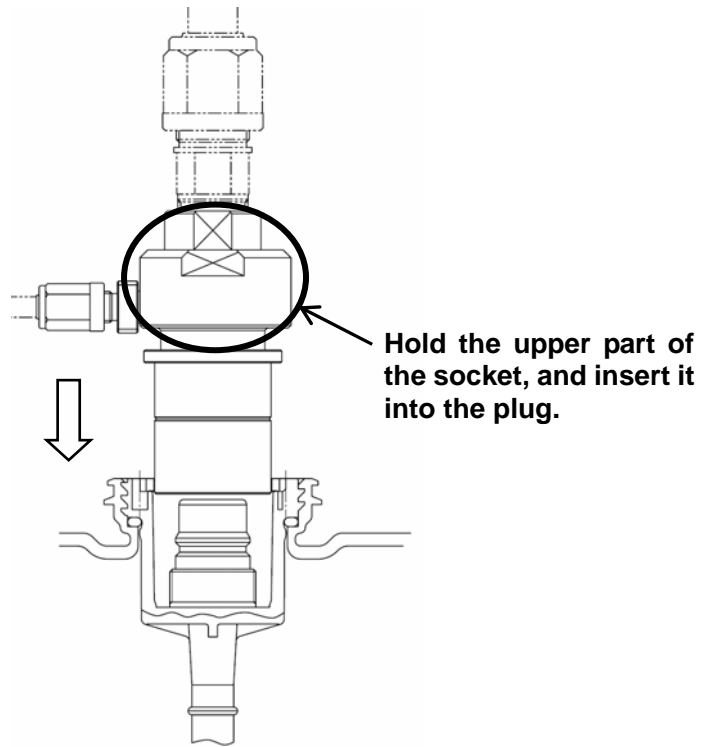

Figure 4



Never pull in the sleeve when connecting the socket, or the socket cannot be connected.

A good example



A bad example



Confirm that the socket is connected securely. (See the photo below.)



Confirm that the V-notch of the sleeve is aligned with the upper surface of the bracket.



* Be careful not to hold the brim of the sleeve while pulling up the plug to avoid releasing the connection.



Pull in the upper part of the socket by hand and, if the socket does not come off, the connection is complete.

8-3 Transferring liquid

Start transferring liquid when all procedures for connecting the connector are successfully complete.

9. Detaching Procedure

9-1 Detaching the socket

Confirm that the container is not pressurized (with no pressure applied).

⚠ DANGER Mandatory struction!!

Release pressure from the piping before detaching the connector. A pressurized condition may cause spouting of chemicals, resulting in personal injury.
Connect the tube without any moment or tension to bend the joint portion.

Pull out the socket straightly while pulling in the sleeve with both hands.

(See the photo and Figure 5 below.)

⚠ DANGER Mandatory struction!!

Always detach the connector at right angle to the surface of container. Detaching the connector at an angle may cause spouting of chemicals, resulting in personal injury.

(1) Pull in the sleeve with both hands.



(2) Be sure to straightly pull out the socket while pulling in the sleeve with both hands.



Figure 5

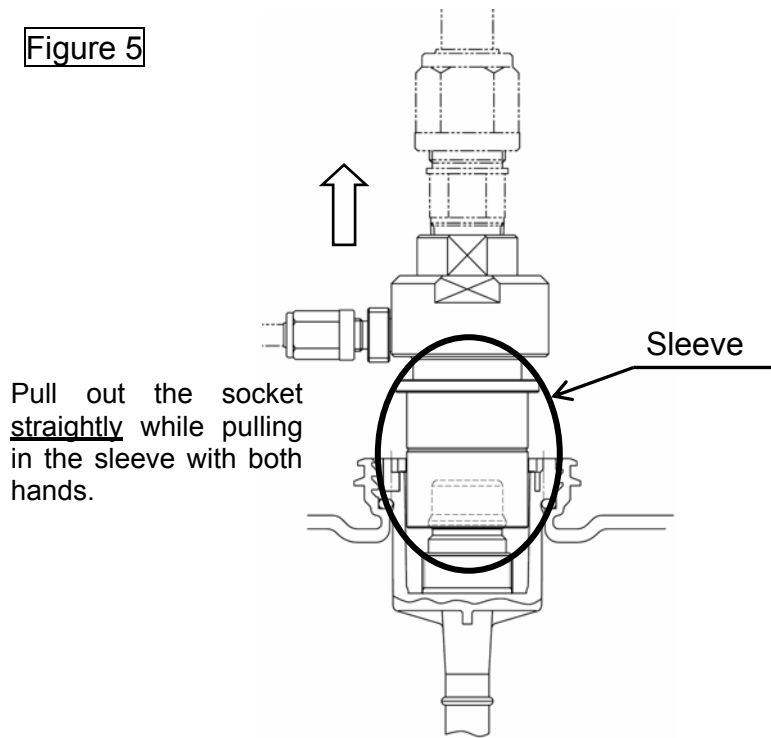

9-2 Attach the cap

Attach the cap. (See the photo and Figure 6 below.)

Torque : 1.5 ~ 2.5[N·m]



When you tighten the cap. Please check top surface of the cap for being alignment with the top surface of the bracket.

CAUTION

Put the special jig into the cap and tighten it with a torque wrench. Excessive or inadequate tightening may cause breakage or liquid leakage.

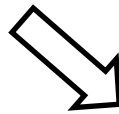

Tighten the cap with
1.5 ~ 2.5[N · m].



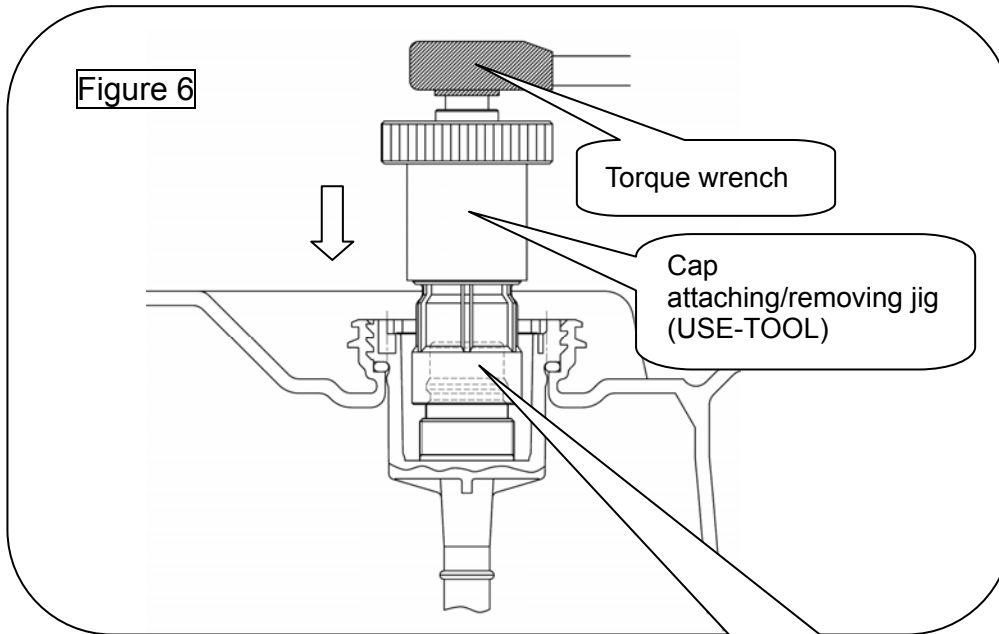

* Screw down the plug so that the upper surfaces of the plug bracket and the cap become in the same plane with no floating of the cap as shown in the right figure.

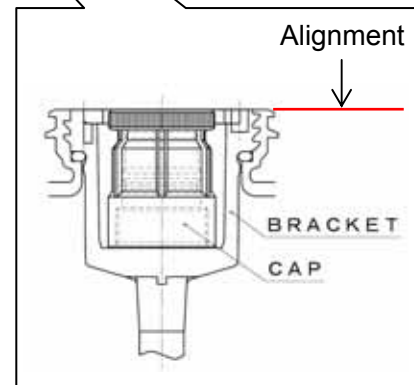

Because of being made of plastics, do not tighten the screw excessively.
Excessive tightening may break the product.

10. Maintenance and Inspection

CAUTION

Surpass Industry is not be liable to any failure or leakage of the product due to O-Ring replacement and/or disassembly performed by any parties other than Surpass Industry.
If you are not confident of success in maintenance work, please call Surpass Industry.

10-1 Daily Inspections

Inspect the following items every day before and after the operation. Whenever the inspection detects any abnormality, take a corrective action.

- Adhesion of coarse particles, dust or dirt
- Liquid leakage from the piping or connecting part
- Looseness of bracket
- Liquid leakage from the O-ring part

11. In Case of Breakdown

Symptom	What to check	Countermeasures
The socket cannot be connected to the plug.	Check if you pull in the sleeve of the socket when connecting. Check if the socket is compatible with the plug.	Connect the socket without pulling in its sleeve. Conform the compatibility. (Please contact us.)
Liquid does not flow.	Check if the socket is connected securely. Check if it is shut in the position other than the socket.	Insert the socket completely into the plug to connect. Check the tube. If it is shut, make it open.
The socket cannot be detached.	Check if the container is pressurized. Check if you pull in the sleeve of the socket when detaching.	Release pressure. Pull out the socket while pulling in the sleeve with both hands.

Notify your nearest sales office for problems not listed above.

12. Warranty

~ Plug warranty ~

This product is developed for the purpose of single-use. We cannot guarantee all responsibility of the guarantee of a product and a secondary calamity, etc.

~ Socket warranty ~

The warranty runs for one year after the day when Surpass Industry products are delivered from Surpass factory in Japan. In case Surpass Industry should agree in writing that the defects in performance or material were caused by faulty design or workmanship of Surpass Industry, replacement products will be supplied free of charge. This warranty shall not be applied to any defects caused by misuse, alteration, neglectful treatment, and neglect of our recommendations or instructions.

In addition, we are not be liable to any direct or consequential loss, damage, and personal injury due to an unauthorized usage in combination with other products and an improper usage outside of the specifications. Our product warranty shall be limited to replacement of product.

Replacement with expense to the purchaser shall be applied to the followings:

Any defective products caused by usage that is not described in the Instruction Manual.

Any defective products caused by neglectful treatment.

Any defective products caused by decomposition, alteration, and improper adjustment or repair.

Any defects of products caused by acts of God including natural disaster or fires.

Consumables and accessories.

The logo for Surpass Industry Co., Ltd. features the word "SURPASS" in a bold, blue, sans-serif font. A small red dot is positioned above the letter "S".

Surpass Industry Co., Ltd.

2203 Shimooshi, Gyoda-shi, Saitama 361-0037 Japan

TEL: +81 48 554 9760 FAX: +81 48 554 9906

URL: <http://www.surpassindustry.co.jp>

© 2011-2012 Surpass Industry Co.,Ltd. All rights reserved.